

Wilson® VH3100 & VH3300

Automatic Vickers/Knoop Hardness Testers

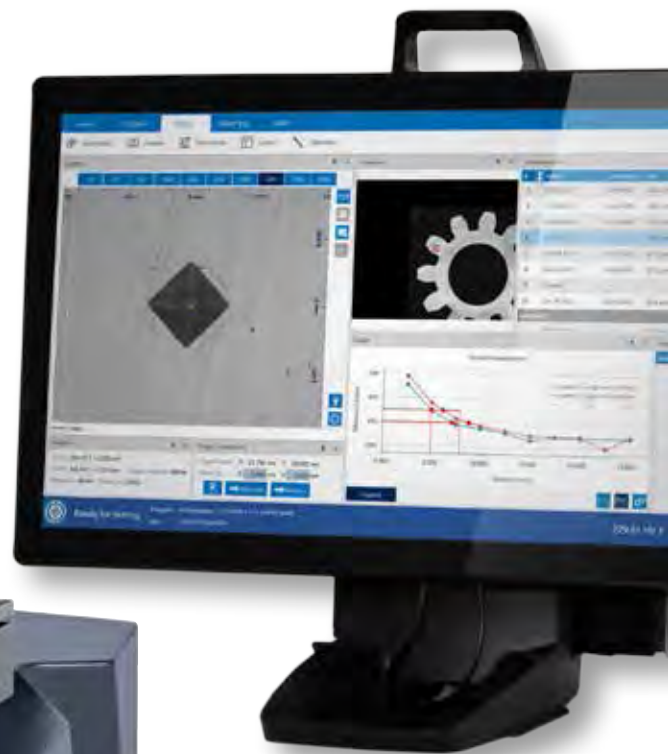



Table of Contents

Wilson VH3100 & VH3300 overview.....	3	DiaMet™ Software Overview.....	15
Excellence in Hardness Testing.....	5	DiaMet™ Software features.....	18
Customize for your application.....	6	System Configuration Guide.....	20
Accessories.....	10	Specifications.....	22
System Overview.....	12		

Wilson® VH3100 & VH3300 Automatic Vickers/Knoop Hardness Testers

The Wilson Fully Automated Hardness Testing System provides a fully integrated platform for your complete Vickers and Knoop hardness testing needs. From leading edge modular frame, stage, and optics designs to a fully featured User Interface, our VH3100 and VH3300 Testers can be built to meet your Application needs today, tomorrow, and into the future.

The DiaMet™ Hardness Automation Software provides the User of the VH3100 and VH3300 hardness testers an efficient and fully automated environment to develop and execute tests that maximize the precision of the tester system with the minimum investment of time possible

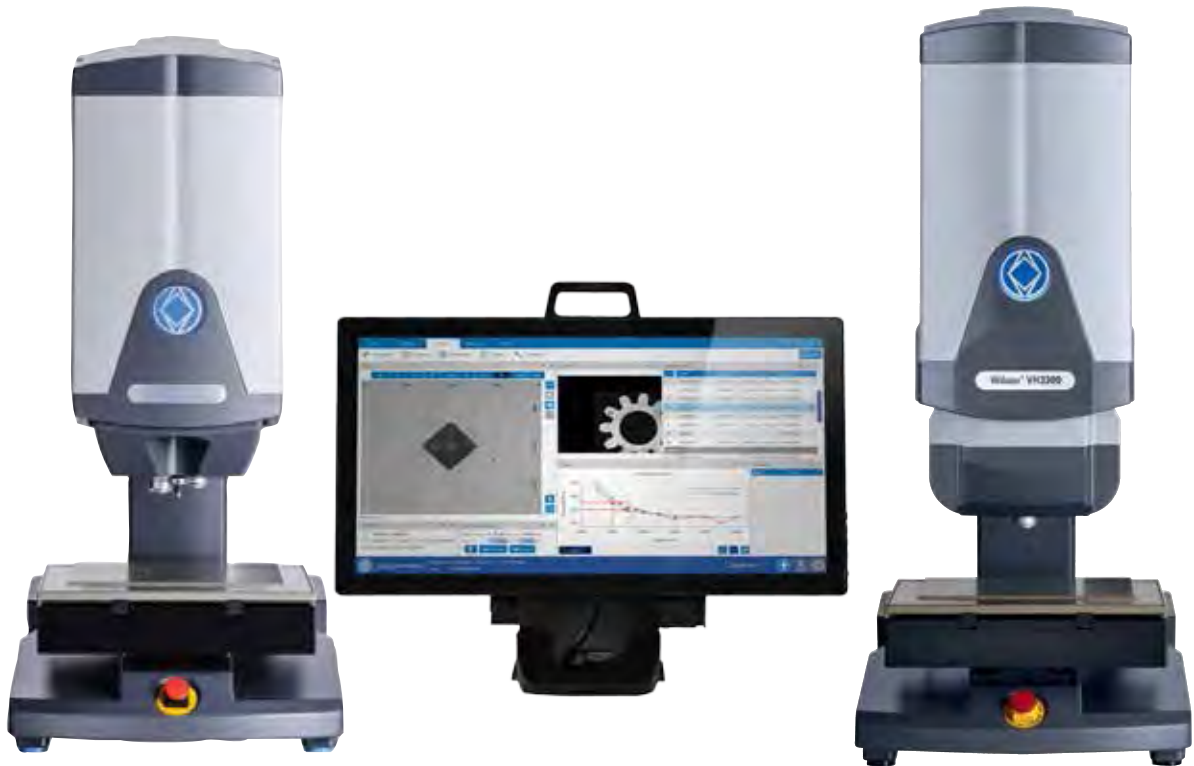

Load Range & Hardness Scales

Load range is important as proper load range and scale is crucial to accurate testing. The Wilson VH3100 tester can accommodate one loadcell and one indenter combination, with 17 load/scale combinations. The wider load range of the Wilson VH3300 can

be populated with up to three loadcells and indenters resulting in a load range of 10gf to 50kgf. This range can be achieved by selecting the low 10N , medium 100N, high 500N or low-high 10-500N load cell.

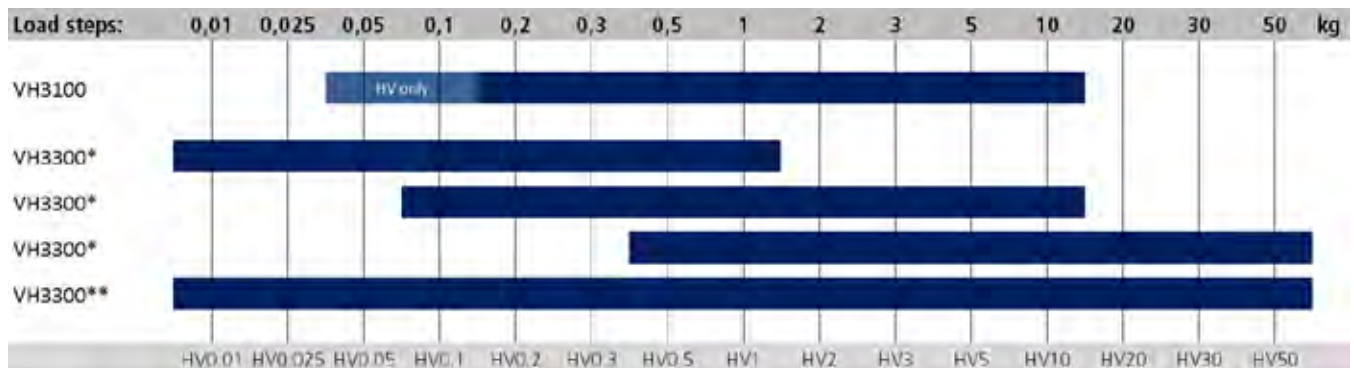

* configuration with one loadcell per scale

** configuration with one low and one high load loadcell per scale





Wilson Instruments



The trend toward tighter manufacturing tolerances and more advanced heat treatment processes for the aerospace, energy, construction and transportation industries require hardness testing systems to be durable while maintaining precise control during critical test data generation. The system and its interfaces must be easy to use, yet flexible enough to meet the increasing demands of the testing world. The Wilson VH3000 series delivers exceptional performance packaged in a reliable, innovative system that offers superior accuracy, repeatability, improved safety and an overall enhanced user experience.

The global expertise of Buehler is strong as it now includes more than a century of experience from companies such as Wilson Instruments, Wolpert/Amsler and Reichert. The Wilson VH3000 series leverages this proud heritage with loadcell measuring systems, instrumentation, controls, accessories and industry preferred software to provide the ultimate high capacity testing platform capable of performing 150 make and measure indents an hour using a fully automated test program.

Configurability

The VH300 Series Testers with DiaMet™ Hardness Testing Automation Software provides you limitless configurability options to match the correct system with your application. Configure the hardware optics and loadcells in the 6 Position Turret to your needs. Configure the DiaMet software layout and functions to match not only your particular application requirements but also needs and preferences of your Operators to maximize their comfort and efficiency.

From color selections, Filar lines graphics, and overlay options, the DiaMet Hardness Testing Automation Software is flexible enough to be the interface that you require. With so many options in Hardware and Software configurations, there is sure to be the exact system for your application.

Wilson® VH3100 & VH3300

Customizable for your application

Process control or Research & Development? Most use of hardness testing systems falls into these two categories. Two completely different tasks, both with need for a Vickers/Knoop hardness tester. If the applications are so different, why use the same hardness tester? Buehler provides the solution in the Wilson VH3100 and VH3300.

Taylor the single indenter Wilson VH3100 configuration to fit the 24/7 demands to guard your internal processes and end up with a lean and dedicated hardness tester. Need to expect the unexpected? Or simply have a wide range of customer demands to satisfy? Than the 6 position turret of the Wilson VH3300 offers you the flexibility to cover the complete Vickers and/or Knoop range with only a few mouse clicks.

Virtual Turret

The single indenter Wilson VH3100 is the fast workhorse of the line, with one indenter, two objectives and optional overview camera. This system significantly reduces system complexity by aligning indenters, objectives and overview camera at a fixed position. All turret positioning is controlled by the high speed stage, while the test head stays stationary. The lack of moving parts, actuators and sensors, simplify adjustments and reduce service needs.



6 Position Star Turret

Those laboratories that need to serve an extremely wide range of applications and those who need to expect the unexpected can be well served with the three indenter Wilson VH3300. Depending on its configuration, this unit can cover a load range from 10grams to 50kilograms. Its fast six position turret also accommodates the optional overview optics.



Collision Resistant System

The Collision Detection System prevents indenter or objective damage by detecting unintended obstructions in the test path. The motion systems is continuously monitored during the test process and system movement is instantaneously stopped if an obstruction is detected. The Collision Detection System provides an unparalleled, unique benefit for operations, while reducing downtime due to damage caused by collision.



VH3100:	√		√
VH3300:		√	√



Snap Grip

Imagine installing a spare indenter or switching between Vickers and Knoop without any alignment effort. This is achievable with the optional Snap-grip on the Wilson VH3100 as each indenter is prealigned in its own snap-grip holder. Changing indenters is simplified as it can be changed in seconds without the need for tools, set-up or alignment verification.



Closed Loop Load Control

Fast, precise, and reliable testing with a sophisticated closed-loop electronic force measuring system and high precision "in-line" load application mechanics. With all critical parts on one axis and a minimization of moving parts, this closed loop control prevents load overshoot from happening, while compensating for friction and wear over time.

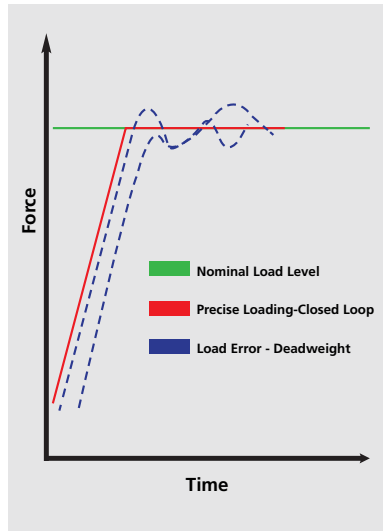

Overshoot protection

External influences, like people bumping into the tester during the indent process, result in a shock, which often is too major for the closed loop system to compensate for. These events result in wrong hardness results, beyond the operators awareness.

The built-in overshoot protection detects load overshoots and aborts the indent process when the maximum test load is exceeded. By doing so, soft readings caused by load overshoots are a thing of the past.



√	√	√	VH3100
	√	√	VH3300

Wilson® VH3100 & VH3300

Customizable for your application

Overview Camera & Stitching

The optional built-in high resolution overview camera allows easy navigation over the entire specimen, accurately positions indents and enables photo stitching. The stitch function allows a user to capture their defined area and resolution, then uses the DiaMet™ software to create a composite overview image of the part(s).



Standard or Touchscreen

The Wilson VH3000 series offers the freedom of choice. For swift and easy “click and run” automated operation, use the rugged, high responsive touchscreen in a clean production environment. The large, conventional monitor options might be a more suitable solution for large amounts of reporting and result analysis.



Choose Magnification

Selecting the most suitable objectives is made easy with a wide range of objectives and their fields of view. All objectives are monitored by the collision detection system on both Wilson VH3000 models. Each objective can be used at five different zoom steps, allowing you to measure your indents at the optimum size to meet both ISO and ASTM standards.

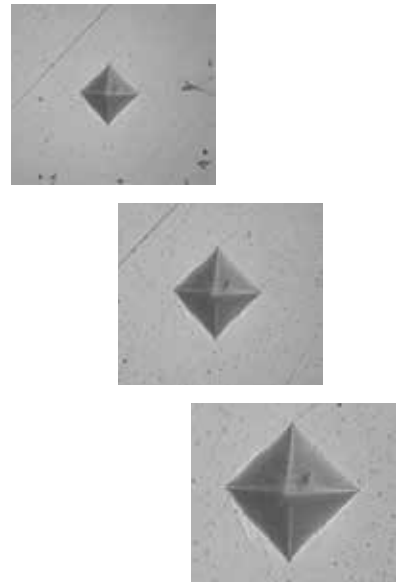

VH3100:	Option	√	2 positions + 5 Zoom Steps per position
VH3300:	Option	√	3 positions*+ 5 Zoom Steps per position

Wilson® VH3100 Application Advantages



Choose a Frame Size

Various applications require various frame sizes. The Wilson VH3100 is available in a compact model, taking up little counter space while providing a test capacity of 4.9in [125mm]. If larger vertical capacity is required, select from the Wilson VH3100 standard frame for 6.7in [170mm] capacity, or the large frame for samples up to 8.5in [215mm].

With 4.1in [105mm] vertical capacity, the Wilson VH3300 is well equipped for testing any mounted sample, weldings and other typical (Micro-) hardness specimens.

High Velocity Stage

Save time and improve efficiency with one of the high speed, high accuracy motorized XY-stages. Available in large or extra-large with travel distances of 7.1x7.1in [180x180mm] or 11.8x7.1in [300x180mm] respectively, these stages enable automated sequencing of multiple samples. The high accuracy and repeatability guarantees precise positioning of indents and allows re-evaluation of all measurement points in the current batch using the camera image.



S, M, L	configuration option	:VH3100
S	configuration option	:VH3300

Vickers & Knoop Accessories

Wilson® Test Blocks & Indenters

Wilson test blocks and indenters provided for a wide range of Vickers & Knoop, as well as Rockwell® and Brinell applications. Certified to a range of international standards including ASTM and ISO, we manufacture test blocks in-house to ensure the highest quality test reference standards available. Test blocks and indenters are certified using the latest standardization and optical measuring technology. We operate our own calibration laboratory, traceable to NIST and are accredited to ISO/IEC 17025 by A2LA®.



Choosing the Correct Support

It's important to keep the test specimen stationary during set-up and testing. The correct support will help ensure that the specimen remains motionless.

A wide range of supports are available, whether testing mounted samples, tapered pieces, small diameter parts, wires or sheet metal. Refer to the Buehler Product Catalogue to select the appropriate support for the application.



Multi-sample holder

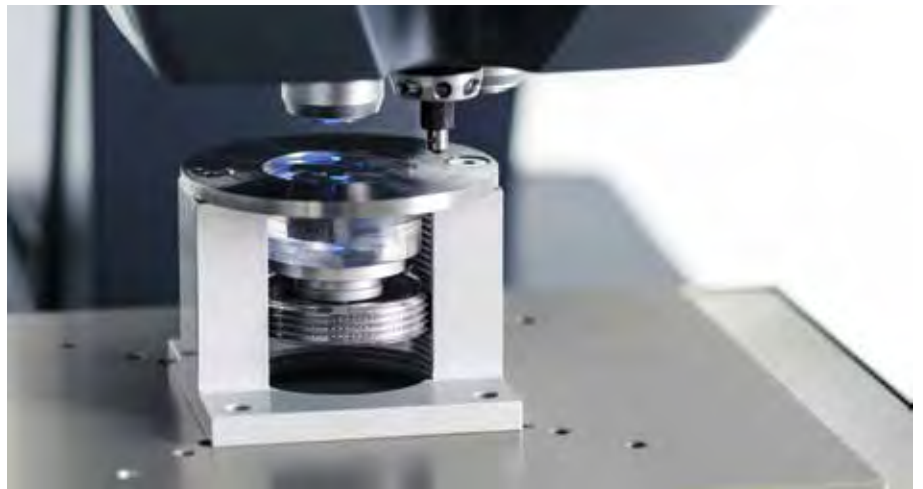

Single sample holder

Tip

Ensure that the both the specimen and the support accessory are free of dirt, grindings, oil or corrosion. Only in this way are accurate and reliable results ensured.

For more background information on Vickers and Knoop testing, please refer to the most current edition of Buehler SumMet.





Modular Design

The Wilson® VH3100 was designed with ease of maintenance in mind. This has resulted in a plug and play modular design, where motorized stage, loadcell, controller and test head are easy to exchange in the field. A smart design in combination with tight production tolerances ensure that the modules can be integrated without significant mechanical adjustments. The Windows® based software platform is future proof, and maintained with regular updates.

The many years of experience in designing rugged hardness testers, combined with this new service friendly concept, will reduce downtime, contributing to overall productivity and keeping cost of ownership at a minimum.



Certified

Built in a facility with an accredited ISO 17025 calibration laboratory, the Wilson VH3100 and VH3300 are assembled by fully trained employees following a certified process. Each machine is delivered with a detailed verification report proving the outstanding quality. The calibration procedures form the strong base of our ISO 9001:2008 certified business processes.

For a traceable on-site calibration, please contact your local service representative

Service

Buehler is a worldwide leader in materials preparation and analysis. As your partner in all aspects, we provide not only a complete line of equipment and consumables, but a strong team dedicated to application knowledge, technical support, and when need be, service. With more than 80 locations across the globe offering telephone and email support, training courses, webinars, and one-on-one custom training, Buehler is there to offer support to our customers, industry and applications. Dedicated to your needs, we strive for fast consumable deliveries, efficient service support and 24/7 access to our online preparation guide.

Service - US
(800) 283-4537
service@buehler.com

**Service - Europe,
Africa, Middle East**
+49 (0)711 4904690
service.wilson@buehler.com

Service - Asia-Pacific
+86 21 6476 6110
asia.service@buehler.com

At a Glance



Wilson® VH3100 & VH3300 Automatic Vickers/Knoop Hardness Testers

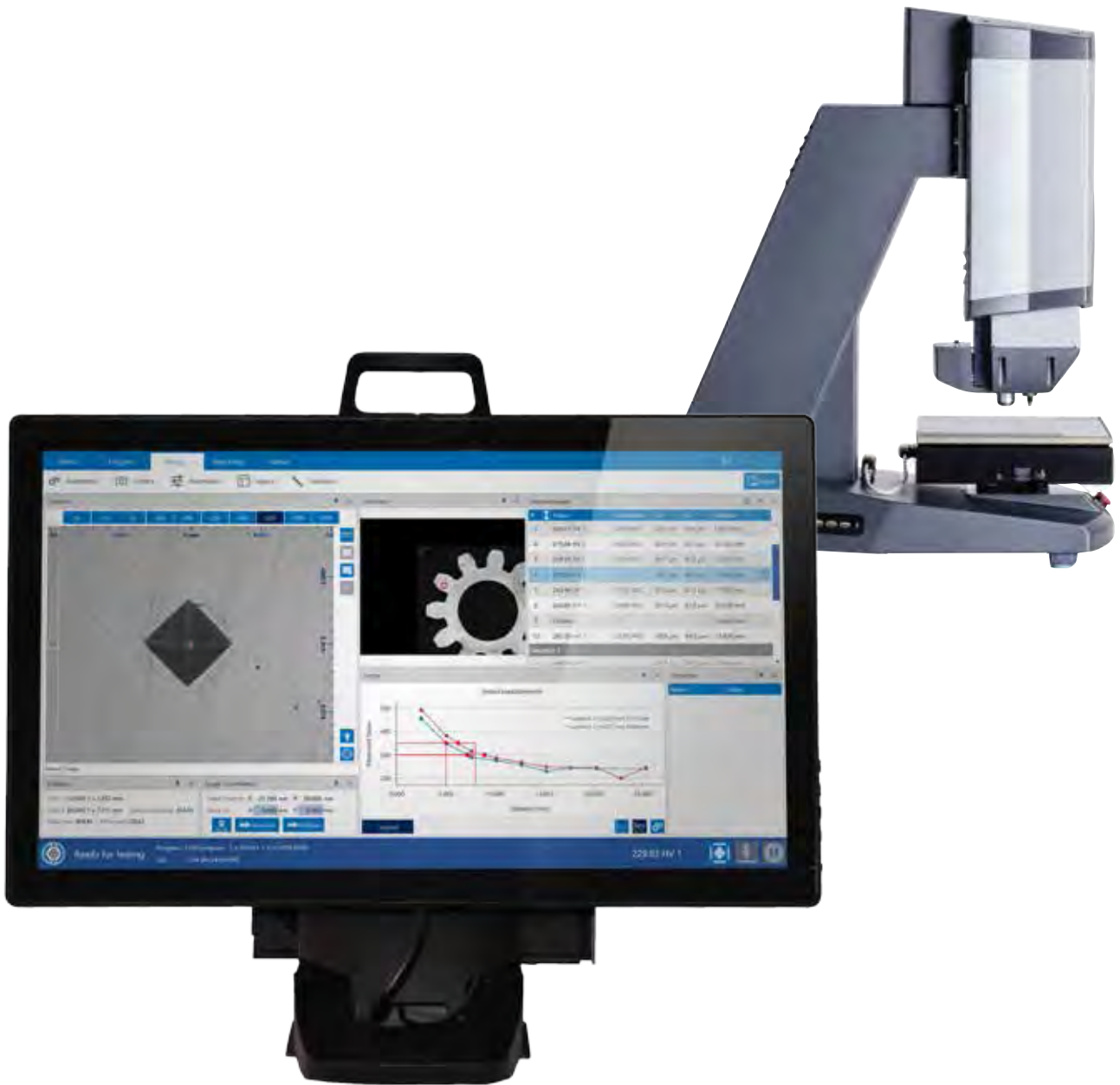

150*
INDENTS PER HOUR

10GF
LOWEST LOAD

50KGF
HIGHEST LOAD

16
LOAD STEPS

6
POSITION TURRET

15
MAGNIFICATION STEPS

** 10s dwell time, depending on load & specimen*

Hardness Testing Made Easy

By removing all unnecessary steps, DiaMet allows users to set-up and run samples in the least possible time. Below is an overview describing a typical workflow within the DiaMet software.

Step 1: Select Program



All application specific parameters like scale, dwell time, pattern, conversion & report template are stored in the same program.

Step 2: Position Pattern

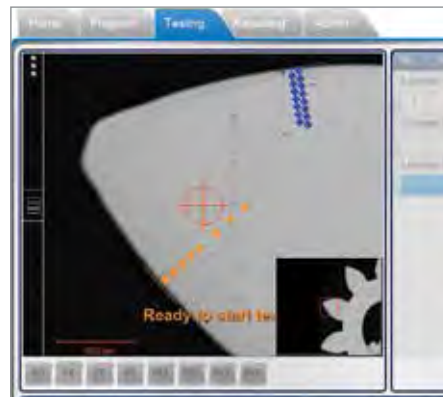

Use the overview camera or infinite scan to see where all indents will be placed. Press start to indent and measure all.

Step 3: Indent & Measure

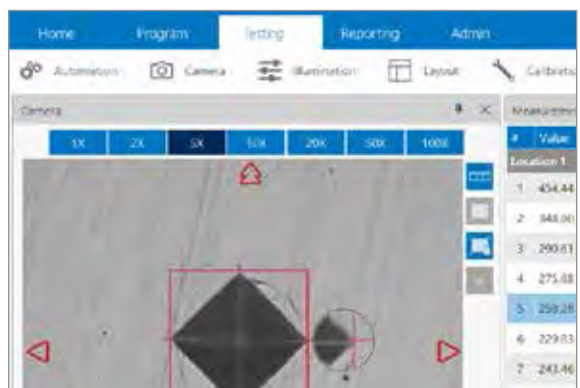

Machine & software make all indentations & measure them automatically, with use of the standard* automatic focus, automatic illumination and automatic measurement functions.

* On fully automatic configurations.

Step 4: Evaluate



Verify the readings in graph and grid and remeasure or re-indent where applicable. Export results to PDF, printer or Excel®.



Automation

Often a high level of automation comes with a high level of complexity both in setup and in operation. Breaking convention, the DiaMet™ software focuses on fast and simple operation to compensate for less experienced operators while still offering a high feature set and flexibility required by expert users. Once a required test pattern is setup, any operator can run the series of Vickers or Knoop indents with a minimum of four clicks or four touches depending on the monitor options.

4 clicks
to run an automated test

Speed

Developed by the same team, the Wilson VH3000 series testers and DiaMet software are completely complimentary to one another. This perfect fit results in the fastest test cycle, fastest auto-focus and fastest auto-measure sequence in its application sequence. By delivering accurate results faster, the user is able to either quickly focus on and control internal processes or to perform additional tests.

5 seconds
or less for Auto-focus & Automeasure

Safety

The Collision Detection System prevents indenter or objective damage by detecting unintended obstructions in the test path. The motion system is continuously monitored during the test process and system movement is instantaneously stopped if an obstruction is detected. The Collision Detection System provides an unparalleled, unique to market essential safety benefit for operators, while reducing downtime and maintenance costs.

Collision Detection
Indenters & Objectives

Versatile

DiaMet is optimized for evaluating Macro-Vickers, Micro-Vickers and Knoop indents according to ISO 6507, ISO 4545 and ASTM E384 standards. A standard DiaMet feature is an automatic symmetry calculation for both Knoop and Vickers. This extra validation, with clear visual indication, helps to ensure the results conform to standards.

Vickers & Knoop

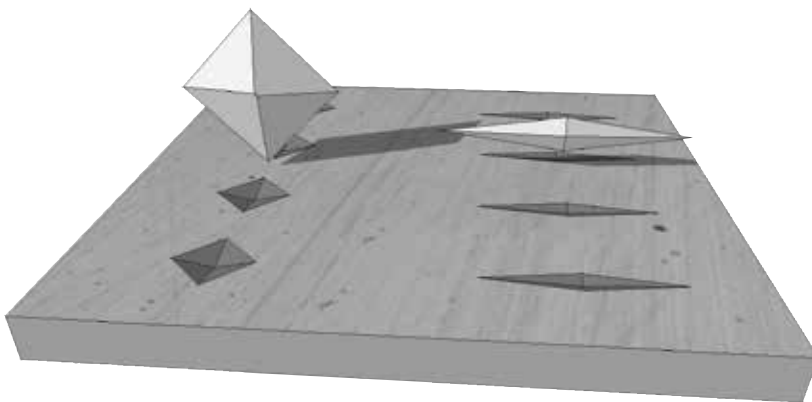

Intuitive & Touch Optimized

Navigating the DiaMet™ software is easy with its clear design and simple and intuitive organization. Tabs on the top of the screen organize primary tools and allows for switching between them. Secondary selections operate in the same fashion, while the status bar provides comprehensive feedback on test progress. With an entirely new look and feel designed for touch panel use, the DiaMet software is simple, useful and smart to work with.

Tab Interface

No deeply buried menus. Jump from Program to Testing, to Reporting.

Magnifications

Direct access to all available zoomsteps. It is possible to preset the desired magnifications in the test program.

Touch Optimized

Now control your hardness tester by touch. Tap, swipe and slide your samples to accurate results.

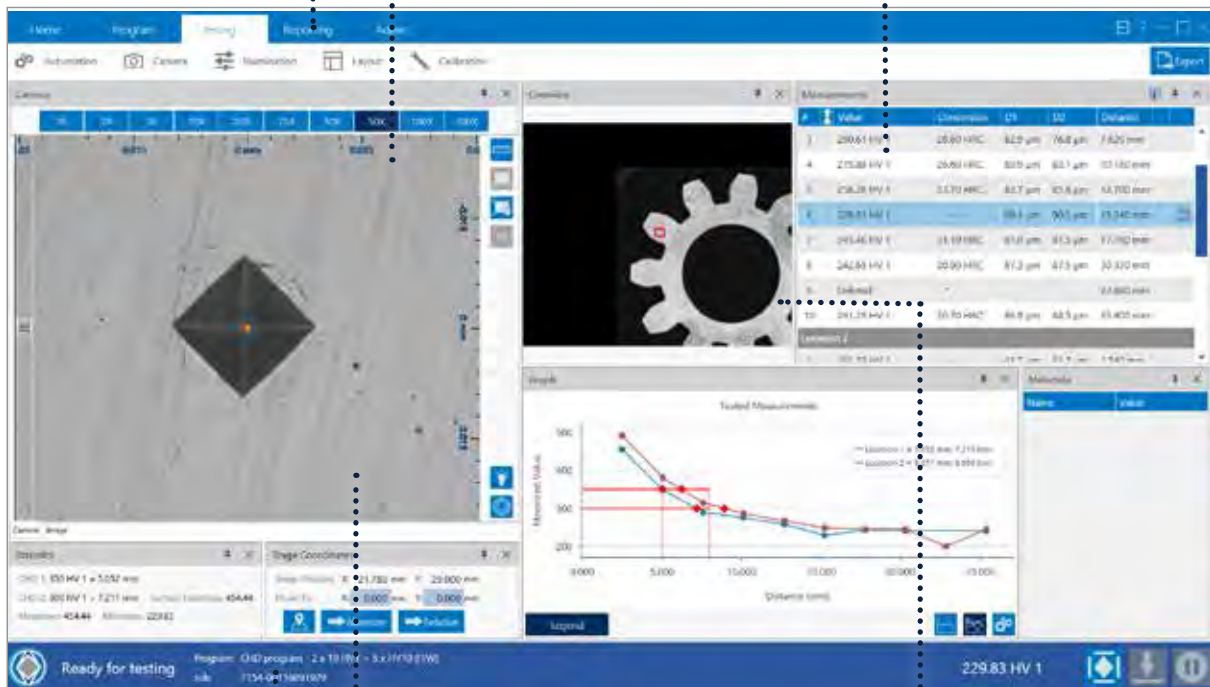

Status Bar

Monitor your hardness tester, program and job status in one overview, with the DiaMet status bar.

XYZ Controls

Besides the traditional Point & shoot and arrow stage navigation, DiaMet introduces Stickynav, where the stage follows your finger on the screen.

Overview

Use the overview window* for easy navigation and fast travel. Zoom and pan over the workspace. (*option in combination with scan option).

QuickTest

The fastest results can be produced using QuickTest. Quickly do a few random HV indents on the part by selecting one of the user defined buttons on the login screen. Each button brings the operator directly to the predetermined parameters in the measurement screen where the indent process can be immediately initiated. QuickTest programs can be password protected to prevent unauthorized use or changes.





Easy Handling

Graphical Pattern Editor

The DiaMet™ pattern editor allows the user to create any number of patterns with a large number of variables. Create patterns with great precision and verify the result in the preview. Combine different patterns and even different loads in one program, and run them fully automatically.

For example 3 CHD rows of 15 indents with HV1, and a core hardness determination out of an average of 5 indents HV10. This is the level of flexibility the VH3000-series offer.



Create
the patterns for the application

Macro View with Navigation Map

Using the macro view function, it's possible to create a composite image of the specimen. The shape and size of the specimen is irrelevant, since the DiaMet software can scan any area within stage limits.

Blend in the overview window to navigate quickly and efficiently from test location to test location.



Navigate
on the sample

Pattern Video Overlay

DiaMet shows the operator where the indents will be made, even before the actual indent process takes place.

The pattern video overlay function helps whilst positioning multiple test rows all across the specimen. The pattern video overlay scales automatically with every magnification, even within the macroview.



See
where to place indents

Software Features

Auto-illumination



Repeatable, repeatable, repeatable – the DiaMet™ software automatic illumination adjusts to the correct illumination level on whatever sample, wherever on the sample independent from material (steels, tool steels, carbides, coatings).

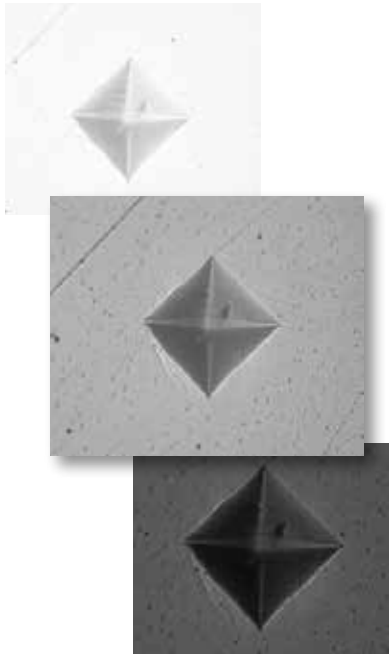

Repeatable
Brightness & Contrast

Auto-focus



Astonishing- observe how the software finds focus from a distance as far away as 30mm or more. Enjoy the shear AF-speed when focusing at close range. The DiaMet software Auto-focus algorithm sets new standards.

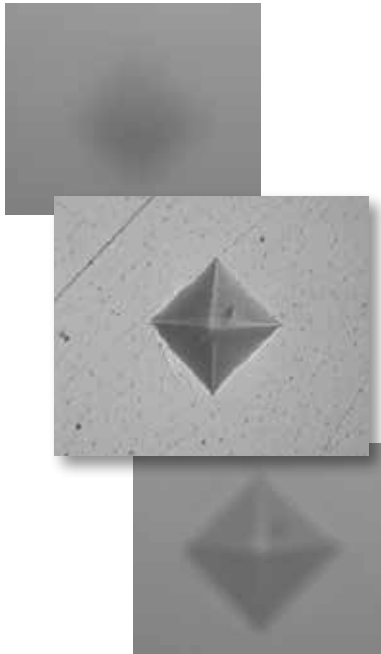

Repeatable
Sharpness

Auto-Measurement



Manual positioning of filar lines is no longer required with the DiaMet software's refined measurement algorithm. Maintain control by switching to manual measure mode and adjust measurements by touch or mouse. Enable the automatic indent symmetry check on demand for further standards confirmation.

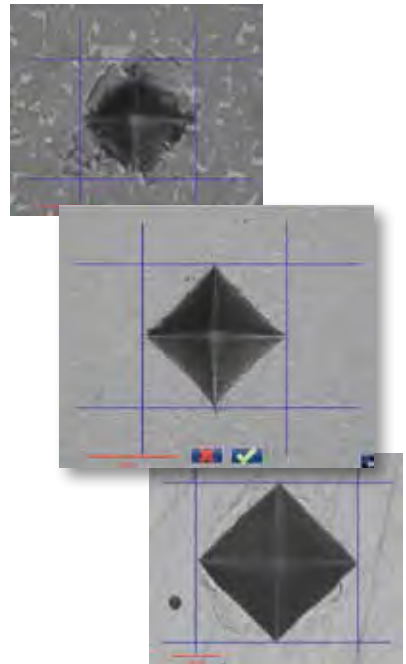

Repeatable
Results



Configure your personal layout, accessing as many measurement aids on the screen as needed. Filar lines can be colored to achieve the best contrast to your specimen, a ruler can be added to provide reference during navigation and positioning, and you can pop up the magnifier glass to help manually position the filar lines.

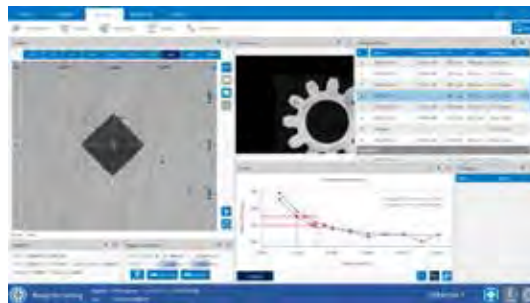
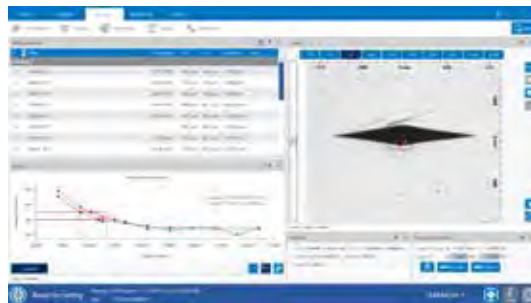
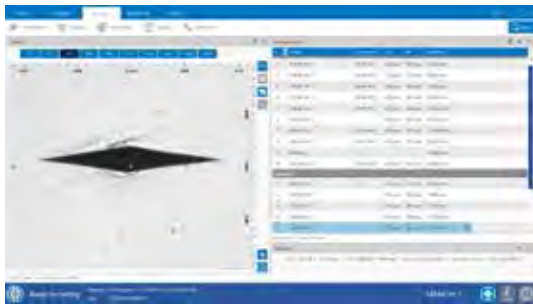

Dual Monitor Option

Having two screens revolutionizes the way you work allowing you to display all graphs and results on one screen while operating the hardness tester and evaluating indents on the other. The flexibility offered by DiaMet one can configure the dual monitor according to personal preference.



System Configuration

Tip: Use as quotation worksheet :

Step 1: Frame

Select only one:



Wilson VH3100

- 3+1 position virtual turret

- W3101 0,2-10kgf range
- W3102 0,05-10kgf range



Wilson VH3300

- 6 position motorized turret
- 0,010 - 50kgf load range*

*depending on configuration

- W3200

Step 2: Monitor

Select only one:



21,5" Touch screen

- 1920x1080 resolution
- Capacitive touch screen

- W3100-B03



24" Full HD monitor

- 1920x1080 resolution

- W3100-B04

Step 3: Motorized Stage

Select only one:



Standard size

- 180 x 180mm

- W3100-C02 for VH3100
- W3200-C02 for VH3300

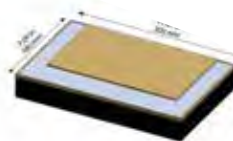

Large size

- 300 x 180mm

- W3100-C03 for VH3100

Marcel: I cannot crop this sufficiently

Step 4: Vertical Test Capacity

Select only one:

Wilson VH3100

- W3100-D01 - height 125mm
- W3100-D02 - height 170mm*
- W3100-D03 - height 215mm*

* max. vertical stroke: 160mm

Wilson VH3300

- W3200-D01 - height 105mm

Step 5: Test Load

Select only one::

Select between 1 and 3:

Wilson VH3100

- W3100-E02 - 100N loadcell



10N
(10gf - 1kgf)



100N
(50gf* - 10kgf)



500N
(500gf - 50kgf)

Wilson VH3300

- W3200-E01 - 10N loadcell
- W3200-E02 - 100N loadcell
- W3200-E03 - 500N loadcell

continue on next page

VH3100

VH3300

Step 6a: Indenter Holder

Select only one: - VH3100 only:



Standard holder
 W3100G01



SnapGrip Holder
 W3100G02

Step 6b: Indenter

Select one per loadcell:



Vickers indenter
• Straight-sided diamond pyramid
• 136°
• Certified to ISO/ASTM
 W9100687



Knoop indenter
• Straight rhombic diamond pyramid, 172°
• Certified to ISO/ASTM
 W9100684

Step 7: Objectives

VH3100 select up to two:



5x LWD
FOV: 1000µm



10x LWD
FOV: 500µm



20x LWD
FOV: 250µm



50x LWD
FOV: 125 µm



100x LWD
FOV: 75µm

VH3300 must choose 2 or 3:

Step 8: Overview Function

Optional



Overview Optic & Scanning
• Separate overview camera
• Incl. Scan & stitch function in the DiaMet software
 W3100F01

Overview Optic & Scanning
• Turret integrated overview
• Incl. Scan & stitch function in the DiaMet™ software
 W3200F01

Step 9: Sample Holder

Optional

Technical Specifications

Hardness Tester Specifications



Approx. Weight: 82.7 lbs [37.5kg] *without monitor*
 Approx. Monitor Weight: 11.5 lbs [5.2kg] *excluding arm*

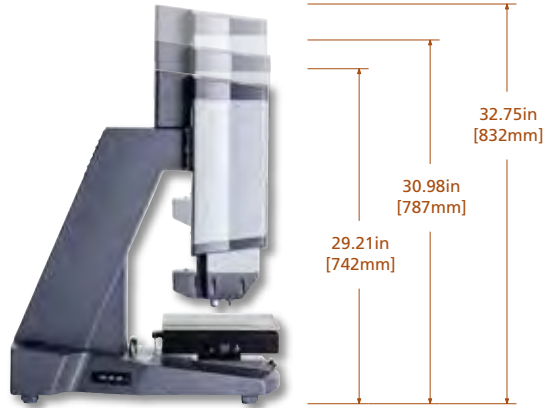

Wilson VH3100

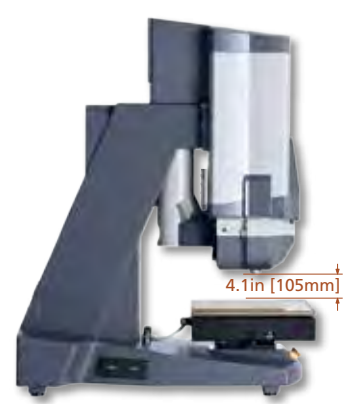

Wilson VH3300

	Wilson VH3100	Wilson VH3300
Scales	HV, HK	
Turret	Automatic 3 position + overview	Automatic 6 position incl. overview
Indenter positions	1 (optional with SnapGrip)	upto 3 (select)
Test Load (select)		Small loadcell (10N) 10gf - 1kgf
		Medium loadcell (100N) 50gf - 10kgf
		Large loadcell (500N) 0,5kgf - 50kgf
Test Load Accuracy	±1.5% < 200g, ±1% > 200g	
Force Application	Load Cell	
Dwell Time	1 - 999 seconds	
Standard Compliance	ASTM E384 & E92; ISO 6507, 9385, 4546	
Magnification Range	30X - 2000X with digital zooming	
Overview Camera (optional)	0.5 x 0.5in [13 x 13mm]	
Vertical travel	160mm (55mm support block included for 215mm model)	
Light Source	LED	

Stage Option Specifications

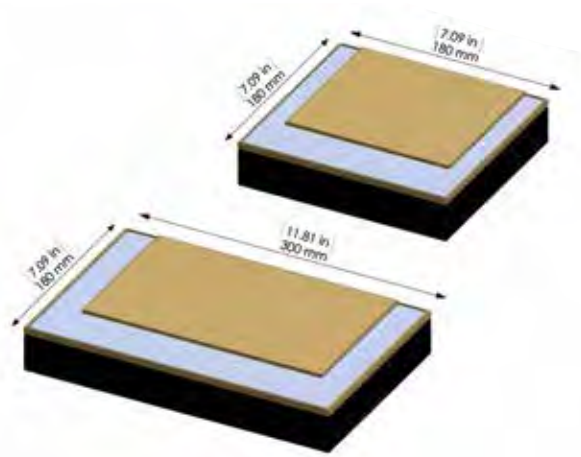

	Large Stage	Extra Large Stage
Travel	7.08 x 7.08in [180 x 180mm]	11.8 x 7.08in [300 x 180mm]
Effective Workspace VH3100	5.5 x 5.7in [140 x 145mm] (5.5 x 4.3in [140 x 110mm] with overview camera)	10.2 x 5.7in [260 x 145mm] 10.2 x 4.3in [260 x 110mm] with overview camera)
Travel Speed	1.06in/s [24mm/s] (XY)	
Physical Resolution	0.5µm	
Repeatability	Better than 5µm	
Accuracy	Absolute accuracy in µm: measuring length in mm / 3 + 5 (from target centre)	
Weight	±22.0 lbs [±10kg]	±30.8 lbs [±14kg]
Overall Size	11.02 x 10.23 x 2.75in [280 x 260 x 70mm]	15 x 10.23 x 2.75in [380 x 260 x 70mm]

Software Specifications

Software	Wilson DiaMet™
Focus	Automatic Focus, with manual override option
Illumination	Automatic Illumination, with manual override option
Measurement	Manual- or Automatic Indent Measurement
Stage Control	Auto traversing for various patterns: CHD, line, circle, matrix and others
Optional Features	Overview scan & stitch

Environmental conditions

Operating Temperature	50 - 100°F [10 - 38°C] (Note: ISO & ASTM standards recommend 68 - 79°F [20 - 26°C])
Humidity	10 - 90% non-condensing
Power	370VAC - 100-240VAC, 50/60Hz
Weight	VH3100: 82.7 lbs [37.5kg] incl. 180x180 stage, without monitor VH3300: 144lbs [65kg] incl. 180x180 stage, without monitor

Buehler products are used throughout the world in manufacturing facilities, quality laboratories, and universities to analyze all types of materials, including:

- Aerospace
- Automotive
- Biomedical & Medical
- Ceramic, Plastics, Composites
- Education, Defense, Government
- Electronics & Optics
- Energy & Construction
- Petrography
- Primary Metals

Buehler Americas

- ★ Lake Bluff, IL, US ● ● ● ●
- Worldwide Headquarters
- Binghamton, NY, US ●
- Norwood, MA, US ● ●

Buehler Europe

- Coventry, UK ● ● ●
- Dardilly, FR ● ● ●
- Düsseldorf, DE ● ● ●
- Esslingen, DE ● ● ●



- Main Offices
- Manufacturing
- Sales
- Service
- Laboratory
- Distributors

Buehler Asia

- Hong Kong, CN ● ● ●
- Shanghai, CN ● ● ● ●

Buehler Worldwide Locations

Other products from Buehler:



Sample preparation equipment includes: abrasive sectioning, precision cutting, mounting, grinding & polishing, electronics and petrography.



Consumables for sample preparation equipment include: abrasive wheels, precision blades, compression mounting compounds, castable systems, silicon carbide abrasive papers, diamond grinding discs, polishing cloths, diamond polishing suspensions, and final polishing suspensions.



Imaging & Analysis and hardness testing equipment include: microscopes, cameras, imaging & analysis software, hardness testers, fixtures, test blocks and hardness software.



Shop online at www.buehler.com. (US, DE, FR and UK only)

For a complete listing of consumables, visit our website at www.buehler.com or refer our Product Catalogue. Buehler continuously makes product improvements; therefore technical specifications are subject to change without notice.

Sectioning

AbrasiMet • AbrasiMatic • IsoMet

Mounting

SimpliMet

Grinding & Polishing

EcoMet • AutoMet • MetaServ

Imaging & Analysis

OmniMet

Hardness Testing

Wilson®



For technical assistance and sales please contact
Pat Lockhart
724-837-6191
QCI Sales, Inc.
pat@qci2.com