



Wilson[®] VH1102 & 1202 Vickers/Knoop Micro-Hardness Tester





The
Ultimate
Deadweight
Micro-Hardness Tester

Versatility for Any Lab



The precision mechanics of the motorized turret, allow for a fast and quiet positioning. Switching between indenter and objective is part of the automated test cycle.

The turret offers either 4 or 6 objective slots, allowing you to fit all the magnification power for your application. The standard 10x and 50x objective can be extended with an 100x objective, thus allowing for a total magnification of upto 1000x. The 5x objective standard on the VH1202, with it's large field of view, allows for more easy navigation on your specimen, for example in automation situations with a motorized XY-stage.

The long working distance objectives (LWD) of the VH1202 minimize the risks of a collision with the specimen, thus limiting downtime and reducing maintenance costs.

Best in Class Optics Ensure Accurate Results

A precise indenting system is a critical requirement for a hardness tester, but must be paired with a system capable of accurately measuring the indentations.

This high quality optical system, with proprietary components, provides an unparalleled image, previously unavailable in hardness testing systems, providing the precision required for the most accurate measurements possible.

The for automation purpose required digital camera can be integrated inside the housing, keeping it safe from dust and dirt as well as preventing it from getting misaligned.



Automatic Load Selection with 9 Load Steps

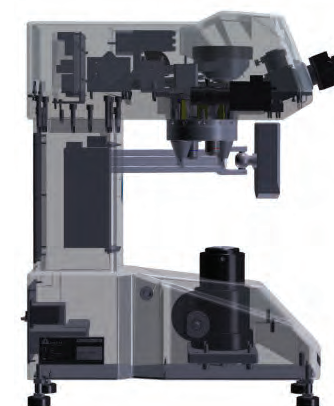

The menu controlled automatic loadselection eliminates the need for a load selector knob, avoids human error and ensures an ergonomic operation. And in combination with the DiaMet™ automation software, it is possible to select test loads from the PC.

The wide loadrange with 9 individual load steps, offer testing capabilities from 10gf up to 2kgf in one machine, without the need of changing internal mechanics.

0,01kg	0,025kg	0,05kg	0,1kg	0,2kg	0,3kg	0,5kg	1kg	2kg
HV0.01	HV0.025	HV0.05	HV0.1	HV0.2	HV0.3	HV0.5	HV1	HV2
HK0.01	HK0.025	HK0.05	HK0.1	HK0.2	HK0.3	HK0.5	HK1	HK2

Wilson® VH1102 & VH1202 Features

The Wilson® VH1102 & VH1202 Vickers/Knoop Series Hardness Testers offer a versatile and user friendly solution for a wide range of micro-hardness scale testing. For single scale micro-hardness testing, the Wilson VH1102 Tester is equipped with a four-position turret which includes one indenter position as well as a 10x and 50x objective. For more demanding applications, the Wilson VH1202 tester is equipped with a six position turret, including two indenter positions as well as 5x, 10x and 50x long working distance objectives.

Both units include USB output, nine automatic selectable test forces and an clear full-color touch panel user interface for rapid test method handling and data collection.

Built-in Camera (Optional)

- The camera for PC measurements is protected against dirt and accidental misalignment, by accomodating it inside the frame.

0.01- 2kgf load range

- A wide load range, divided into 9 individual load steps

4 to 6 Position Turret

- Up to two indenter positions (Knoop and/or Vickers)
- Fast & quiet motorized operation
- Up to four objectives positions



Advanced Functionality for Leading Industries

The global expertise of Buehler is strong as it now includes more than a century of experience from companies such as Wilson Instruments, Wolpert and Reicherter. With the design and manufacturing of the VH1x02 equipment, the DiaMet software and test blocks all in-house by Buehler, system integration is guaranteed. Smart software functions help the user with standards traceability.

The trend toward tighter manufacturing tolerances and more advanced heat treatment processes for the automotive industries require hardness testing systems to be durable while maintaining precise control during critical test data generation. The system and its interfaces must be easy to use, yet flexible enough to meet the increasing demands in the industry.

The Wilson VH1102 & 1202 deliver exceptional performance packaged in a reliable, easy to use system that offers superior accuracy and repeatability against low training requirements. With an optional DiaMet automation package this testing platform is capable of performing 100 make and measure indents an hour using a fully automated test program.

Aerospace



Automotive



Heat Treatment



Smart UI

The Wilson Smart-UI with it's clever Tabs for Testing, statistics and set-up, has transitioned to a large 7" full-color TFT-screen for even more comfort and ease of use. Mounted on a flexible arm, the screen can be adjusted for the perfect ergonomical working position. Data export with a single button press, is what the VH1102 & VH1202 allow with their integrated USB port. Saving your data in CSV format on a thumb drive, allows you to evaluate your data on any PC with MS Excell. It's advanced features include extended statistics, eco-power mode, shape correction for convex or concave shaped specimens. and hardness conversion to Rockwell, Brinell or Tensile strenght according to ASTM E140 and ISO 18625



Automatic Load Selection

- Select your load on the touch screen menu and let the Buehler hardness tester adjust the mechanics for you.

Large Color LCD

- The largest LCD with 7" diagonal, for easy operation
- Only necessary information is shown,
- The rest is found in clear tabular menu structure

USB Output

- Export your data in
- CSV format to Excell



DiaMet™ - Hardness Testing Made Easy

By removing all unnecessary steps, DiaMet allows users to set-up and run samples in the least possible time. Being designed for touch panel use, with an entirely new look and feel, DiaMet is simple, useful, and smart to work with!

Tab Interface

No deeply buried menus. Jump from Program to Testing, to Reporting.

Magnifications

Direct access to all available zoomsteps. It is possible to pre-set the desired magnifications in the test program.

Tab Interface

Now control your hardness tester by touch. Tap, swipe and slide your samples to accurate results.

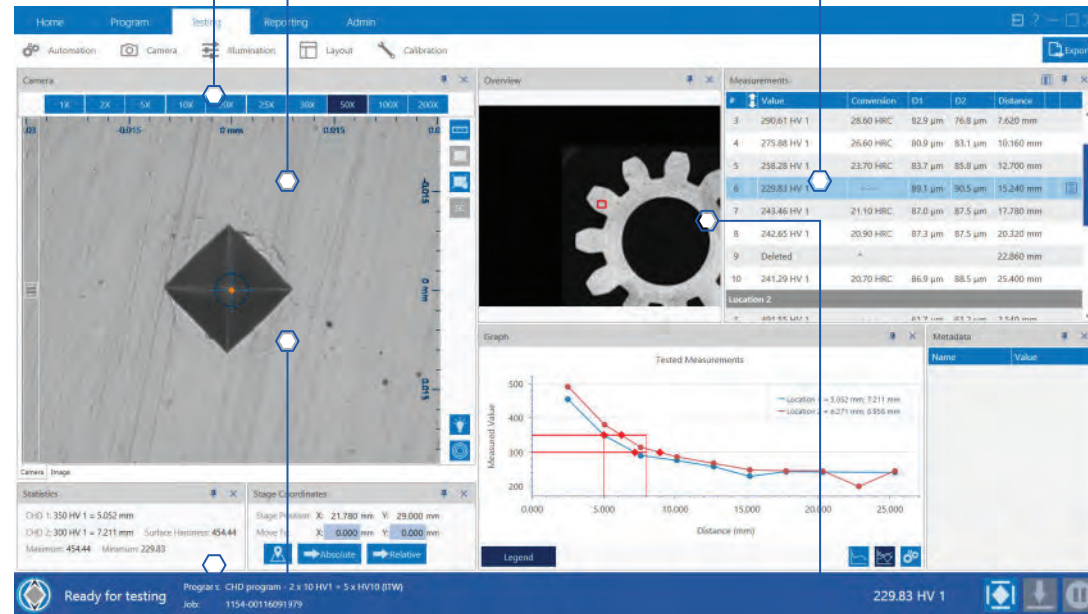

Status Bar

Monitor your hardness tester, program and job status in one overview, with the DiaMet status bar.

XYZ Controls

Besides the traditional Point & shoot and arrow stage navigation, DiaMet introduces Stickynav, where the stage follows your finger on the screen.

Overview

Use the overview window* for easy navigation and fast travel. Zoom and pan over the workspace. (*option in combination with scan option).

Expert Control & Evaluation Software

Often a high level of automation comes with a high level of complexity both in setup and in operation. Breaking convention, the DiaMet software focuses on fast and simple operation to compensate for less experienced operators while still offering a high feature set and flexibility required by expert users. Once a required test pattern is setup, any operator can run the series of Vickers or Knoop indents with a minimum of four clicks or four touches depending on the monitor options.

DiaMet is optimized for evaluating Macro-Vickers, Micro-Vickers and Knoop indents according to ISO 6507, ISO 4545 and ASTM E384 standards. A standard DiaMet feature is an automatic symmetry calculation for both Knoop and Vickers. This extra validation, with clear visual indication, helps to ensure the results conform to standards.

User Defined Programs

Using a set of simple tools, users can customize test patterns in a program. Programs can be saved and used whenever required, edited, copied or amended. Pre-fabricated programs can be loaded and amended to suit a particular application. Save set-up time and improve positioning accuracy with these automatic testing sequences.

Auto-Measurement

Manual positioning of filar-lines is no longer required with this refined measurement algorithm. Stay in control, and adjust the measurements by manipulating the filar lines. The manual measure mode is designed used by touch and/or mouse. An automatic indent symmetry check for Vickers and Knoop can be enabled on demand.

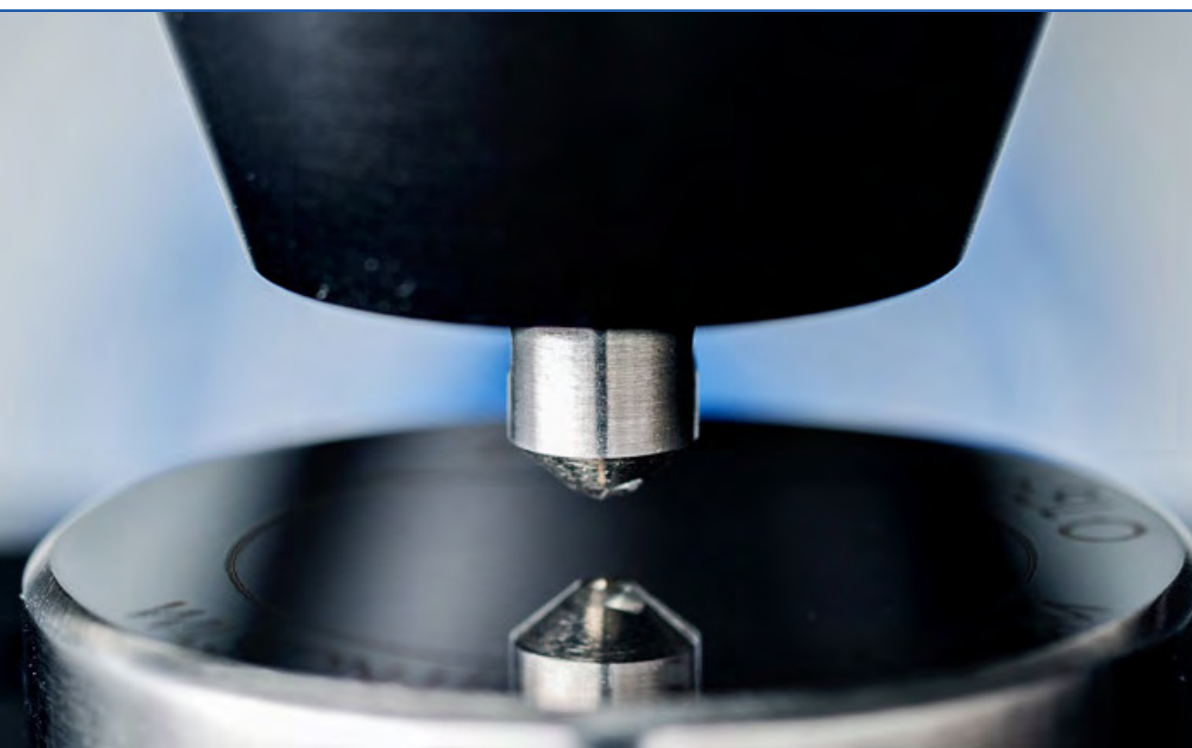
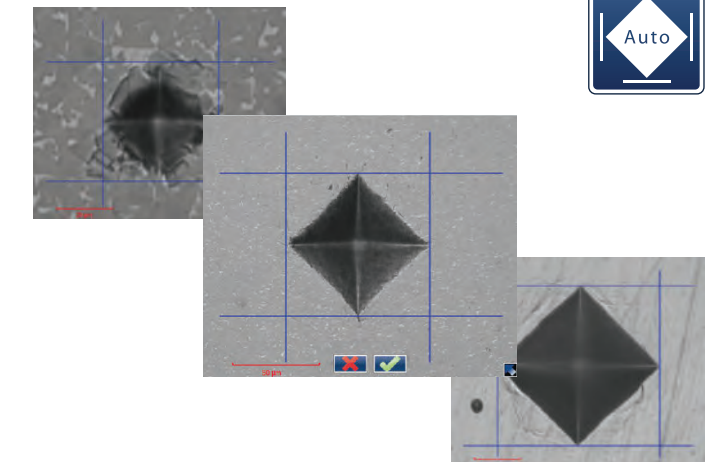
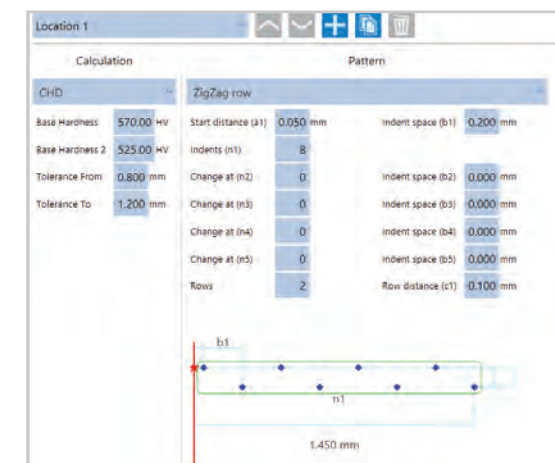

Always a Perfect Fit For User Applications

The Wilson VH1102 and VH1202 can be perfectly configured to fit your application and budget. Operate it in standalone mode for the occasional test, or upgrade it with a Basic version of our DiaMet software for better repeatability and comfort. The 100x100mm motorized stage in combination with the DiaMet Software will upgrade the hardness tester to a semi-automatic system which allows to run automatic traverses. Auto focus of the full automatic systems unlocks the ability to run large series of indents without operator supervision; save time and increase throughput!

Tester Models and Features

	Base	DiaMet Basic	DiaMet Semi Automatic	DiaMet Full Automatic	DiaMet Enterprise
Digital Eyepiece		●	●	●	●
Digital Micrometers		●	●	●	●
Auto Measure		●	●	●	●
Auto Illumination		●	●	●	●
Motorized XY-Stage			●	●	●
Auto Focus				●	●
Enterprise					●

Stand Alone

Effectively measure indents using the high-quality digital eyepiece and evaluate the readings on the comfortable 7" color screen. Data can be exported by using the USB port.



DiaMet™ Software Options For Micro-Hardness Testing

DiaMet Basic

The basic package offers a simple and comfortable indentation measurement on PC and allows for a fast & safe data storage. The standard automatic measurement reduces overall testing time, as well as improves operator repeatability.



DiaMet Semi-Automatic

With the Semi-automatic version, the user defined pre-programmed indent patterns are placed automatically by means of a motorized 100 x 100mm XY-stage. This saves valuable operator time.



DiaMet Full Automatic

In Full-automatic mode, the motorized XY-stage for positioning is completed with an Autofocus capability on the Z-axis. This allows the software to indent and measure multiple indents completely operator independent.



DiaMet Enterprise

Enterprise expands the Full automatic system with cutting edge capabilities features such as hardness mapping, scanning and pattern templates.



Technical Specifications

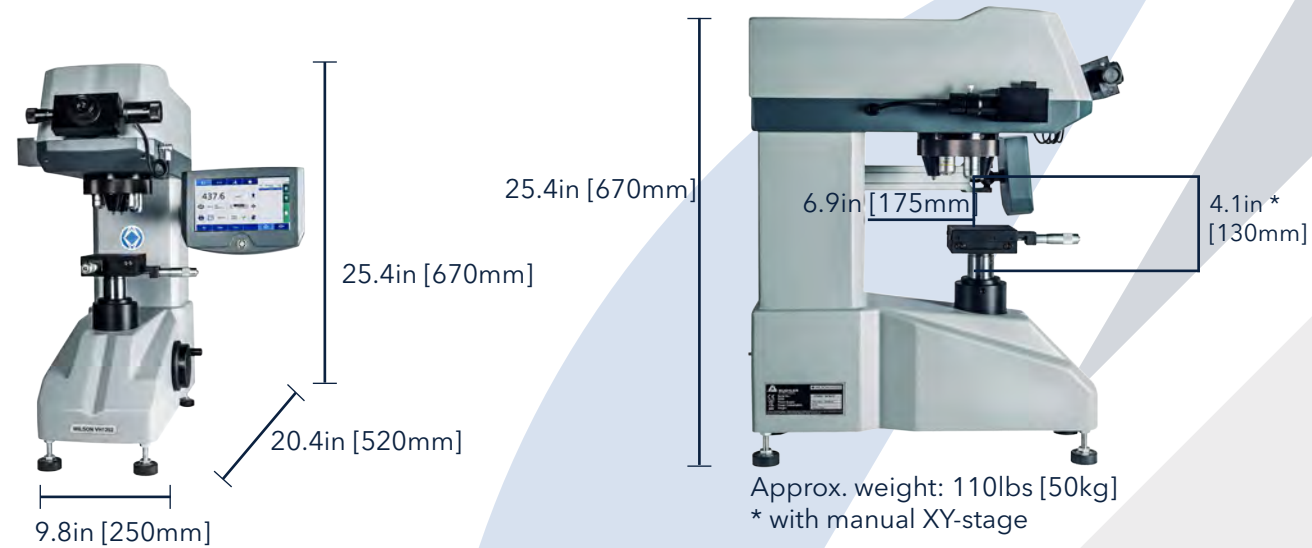

VH1102

VH1202

Scales	HV (Vickers), HK (Knoop)	
Turret	Motorized	
Indenters	1 indenter position Select Vickers or Knoop	2 indenter positions Select Vickers and/or Knoop
Standard Objectives	10x & 50x Regular	5x, 10x & 50x Long Working Distance
Total Magnification	100x, 500x	50x, 100x, 500x
Test Loads	0.01 - 0.025 - 0.05 - 0.1 - 0.2 - 0.3 - 0.5 - 1 - 2kgf	
Test Load Accuracy	±1.5% < 200g, ±1% > 200g	
Test Cycle Type	Motorized dead weight	
Standard Compliance	ASTM E384 & E92; ISO 6507, 9385, 4546	
Light Source	LED	
XY-stage Options	Manual 100 x 100mm stage, 25 x 25mm travel Motorized stage 100 x 100mm travel (with PC software only)	
Data-out	USB and RS232	
Software Options	Options from basic camera kit to full automatic system available	
Operating Temperature	50 - 100°F [10 - 38°C]	
Humidity	10 - 90% non-condensing	
Power	100 - 240VAC, 60/50Hz	

Ordering Information

VH1102 & VH1202 Package Options

Testers	Stand Alone Analog XY	Stand Alone Digital XY	DiaMet Manual (Incl. AM) Analog XY	DiaMet Manual (incl. AM) Digital XY	DiaMet Semi (XY & AM)	DiaMet Full Auto	DiaMet Enterprise
VH1102 Vickers	W1102D01	W1102D03	W1102D31	W1102D33	W1102D35	W1102D37	W1102D45
VH1102 Knoop	W1102D02	W1102D04	W1102D32	W1102D34	W1102D36	W1002D38	W1102D46
VH1202 Vickers & Knoop	W1202D01	W1202D03	W1202D31	W1202D33	W1202D35	W1202D37	W120245

Accessories

Part Number	Description	Part Number	Description
W5XLWD	5x Long working distance objective	W9170506	Analogue XY-stage
W10XLWD	10x Long working distance objective	W9170507	Digital XY-stage (ex. Cables)
W20XLWD	20x Long working distance objective		
W40XLWD	40x Long working distance objective		
W50XLWD	50x Long working distance objective		
W100XLWD	100x Long working distance objective		

Wilson® Test Blocks & Indenters

Wilson test blocks and indenters are provided for a wide range of Vickers & Knoop, as well as Rockwell® and Brinell applications. Certified to a range of international standards including ASTM and ISO, we manufacture test blocks in-house to ensure the highest quality test reference standards available. Test blocks and indenters are certified using the latest standardization and optical measuring technology. Buehler operate its own calibration laboratory, traceable to NIST and are accredited to ISO/IEC 17025 by A2LA®. For more information on the test blocks and indenters please see the current catalog or visit www.buehler.com.



Buehler Worldwide Locations

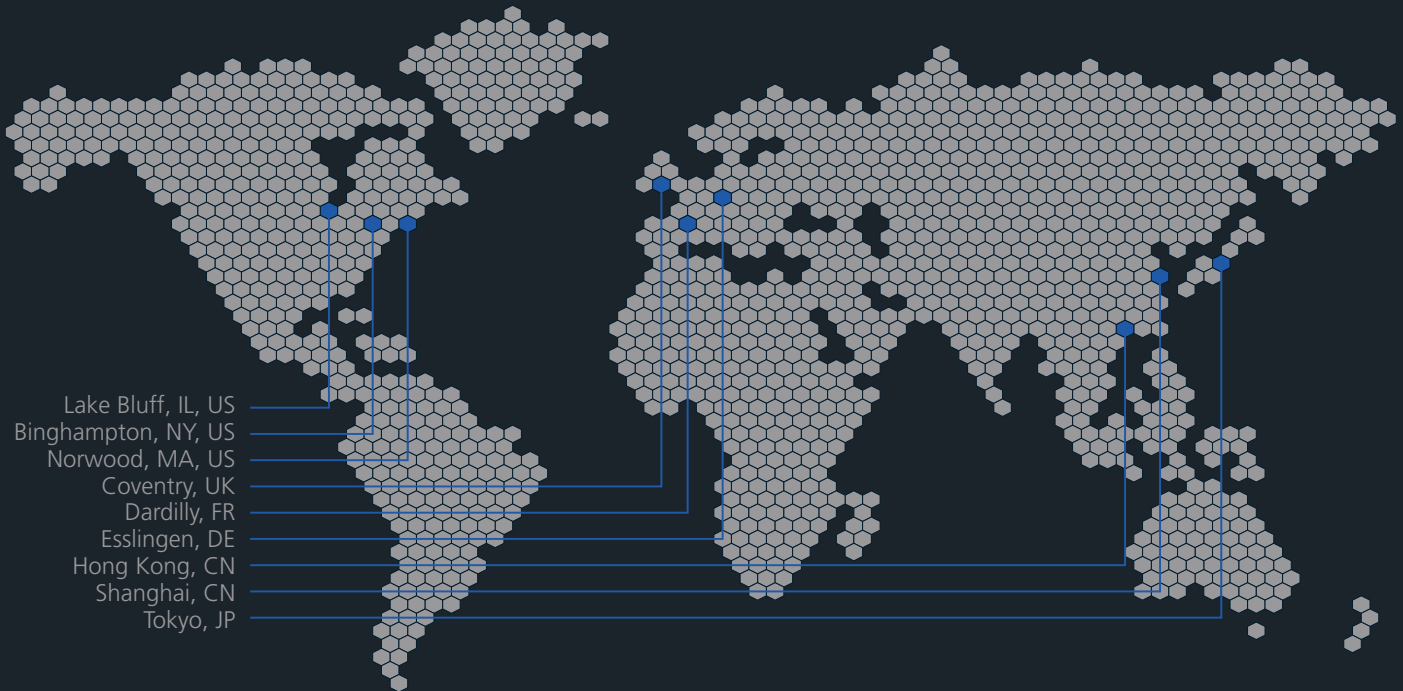

Solutions for Materials Preparation, Testing and Analysis

BUEHLER

41 Waukegan Road, Lake Bluff, Illinois 60044
P: 847 295 6500 | 800 BUEHLER (800 283 4537)
W: www.buehler.com | **E:** info@buehler.com

North America-South America Offices

BUEHLER Worldwide Headquarters
P: 847 295 6500 | 800 BUEHLER (800 283 4537)
W: www.buehler.com | **E:** info@buehler.com

Europe Offices

BUEHLER Germany - Esslingen
European Headquarters
P: +49 (0) 711 4904690-0
E: info.eu@buehler.com

BUEHLER France - Dardilly
P: +33 (0) 800 89 73 71
E: info.eu@buehler.com

BUEHLER United Kingdom - Coventry
P: +44 (0) 800 707 6273
E: info.eu@buehler.com

Asia-Pacific Offices

BUEHLER Japan
P: +81 03 5439 5077 | **F:** +81 03 3452 7220
E: info.japan@buehler.com

BUEHLER Asia-Pacific - Hong Kong
P: +852 2307 0909 | **F:** +852 22721 6659
E: info.asia@buehler.com

BUEHLER China - Shanghai
ITW Test & Measurement (Shanghai) Co., Ltd.
P: +86 400 000 3418 | **F:** +86 21 6410 6671
E: info.cn@buehler.com

Visit www.buehler.com for more information on a Buehler location near you.

